

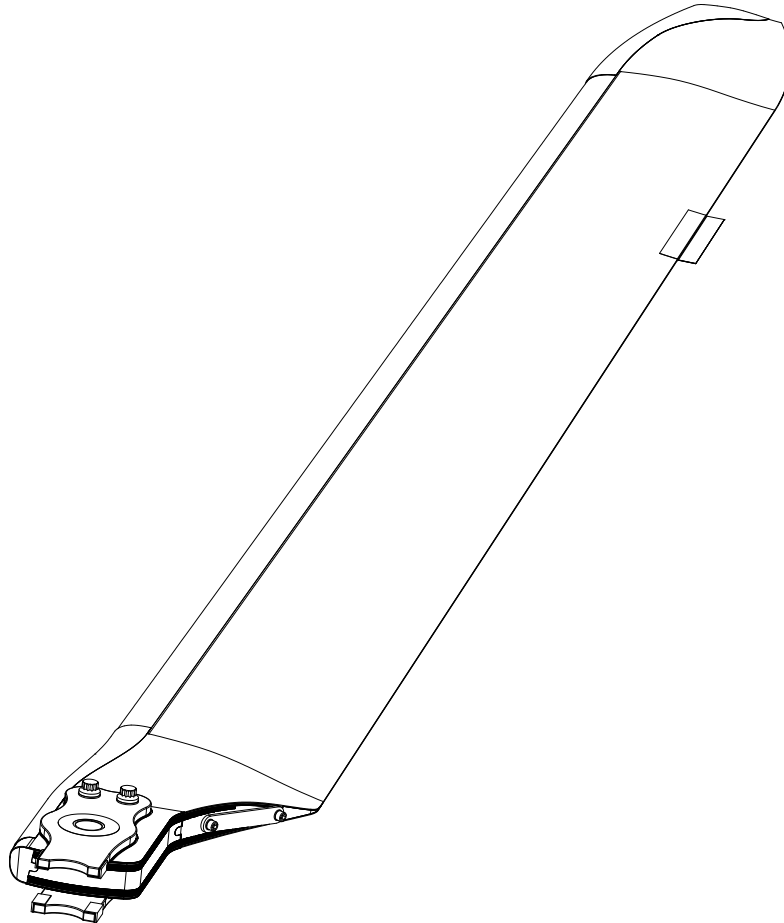

Van Horn Aviation, L.L.C.
1510 W. Drake Drive
Tempe, Arizona 85283

INSTRUCTIONS FOR CONTINUED AIRWORTHINESS



ICA MANUAL No. VMM-MR-206B-501

Main Rotor Blade Assembly 20631000-101
Eligible for Installation on Model 206B

REVISIONS

REV	DATE	DESCRIPTION	APPROVED
N/C	01/27/16	Initial Release	JVH
A	02/02/16	Updated section 4, airworthiness schedule. Added bushing and grip plate inspections. Updated figure 62-1.	JVH
B	02/10/16	Updated section 4, airworthiness schedule.	JVH
C	04/29/16	Updated section 4, airworthiness schedule.	JVH
D	06/08/16	Corrected Grip Assembly part numbers in 62.2.	JVH
E	12/19/16	Expanded 5.10.1 Damage Description. Revised 5.10.4(c.)(d) to add a time requirement in addition to an hour requirement for exposed carbon/epoxy skin aft of abrasion strip trailing edge. Added tap test of blade in 5.4 and 5.5. Renamed figure 5-1 to 5-2. Added new figure 5-1. Revised 62.3.2(c.) to permit use of reflective tape in addition to tracking tabs and permits use of Bell approved trim tab bending and angle measuring tools. Deleted NOTE in 62.3.	JVH

TABLE OF CONTENTS

REVISIONS 2
TABLE OF CONTENTS 3
CHAPTER 0 - INTRODUCTION 4
CHAPTER 4 – AIRWORTHINESS LIMITATIONS 5
CHAPTER 5 – INSPECTION/CHECK REQUIREMENTS..... 6
CHAPTER 11 – PLACARDS AND DECALS 13
CHAPTER 62 – MAIN ROTOR BLADE 13

CHAPTER 0 - INTRODUCTION

0.1 SCOPE

This manual contains information, descriptions, and instructions essential for the continued airworthiness of the Van Horn Aviation L.L.C. 20631000-101 Main Rotor Blade Assembly.

0.2 ARRANGEMENT

This manual follows the Airline Transport Association (ATA) specification 100 numbering system where practical.

0.3 UNITS OF MEASUREMENT

All measurements, tolerances, and other numbers referenced in this manual will be in English units.

0.4 CHANGES TO THE ICA

0.4.1 Changes to text and tables, including new material on added pages shall be indicated by a vertical bar in the outer margin extending close to the entire area of the material affected.

0.4.2 Please send any comments or corrections to Van Horn Aviation L.L.C., 1510 West Drake Drive, Tempe, AZ 85283 USA. Or call 01-480-483-4202.

0.5 DISTRIBUTION

0.5.1 The ICA will be shipped with the original purchase of a 20631000-101 main rotor blade assembly.

0.5.2 The ICA can be found on Van Horn Aviation's website at www.vanhornaviation.com.

CHAPTER 4 – AIRWORTHINESS LIMITATIONS

4.1. AIRWORTHINESS LIMITATIONS SCHEDULE

The Airworthiness Limitations section is FAA approved and specifies inspections and other maintenance required under §§43.16 and 91.403 of the Federal Aviation Regulations unless an alternative program has been FAA approved.

Part Number	Part Name	Airworthiness Limitation
20631000-101	Main Rotor Blade Bonded Sub-Assembly Only	18,000 Hours
20631020-101 20631020-103	Grip Plate Assembly	2,800 Hours*
20631391-1	Bushing, Inboard Blade Root	2,800 Hours
20631392-1	Bushing, Outboard Blade Root	2,800 Hours

*Includes all installation hardware: bolts, nuts, and washers.

FAA Approved: _____



Date: _____

1/24/17

CHAPTER 5 – INSPECTION/CHECK REQUIREMENTS

5.1. PRE-FLIGHT CHECK

No.	Requirements	Airworthiness Criteria
1.	Visually check the main rotor blades for any visible damage such as cracks, blisters, delaminations, or local contour deformation.	See 5.10 DAMAGE LIMITS

5.2. 100 (+/- 10 hour tolerance) HOUR INSPECTION AND ANNUALLY

No.	Inspection Requirements	Airworthiness Criteria
1.	Check the general condition of the rotor blade. Check for skin dents, scratches, or blisters. Check the trailing edge for nicks or delaminations.	See 5.10 DAMAGE LIMITS
2.	Examine tip balance weights for security.	Make sure weights do not move/turn easily.
3.	Inspect the abrasion strips for wear, cracks and edge voids.	Contact Van Horn Aviation if any discrepancies found.

5.3 300 (+/- 30 hour tolerance) HOUR INSPECTION

No.	Inspection Requirements	Airworthiness Criteria
1.	Perform dynamic balance of main rotor.	Balance to .20 IPS or lower.

5.4 1,400 (+/- 30 hour tolerance) HOUR INSPECTION

No.	Inspection Requirements	Airworthiness Criteria
1.	Inspect grip plate assemblies, root plates, and bushings for cracks. Conduct a tap test of blade upper and lower surface*.	Contact Van Horn Aviation if any discrepancies found exceeding damage limits in 5.10 and for grip plate assembly installation instructions.

5.5 2,800 (+/- 30 hour tolerance) HOUR INSPECTION

No.	Inspection Requirements	Airworthiness Criteria
1.	Remove and replace 20631020-101 & -103 grip plate assemblies, 20631391-1 and 20631392-1 bushings. Replace all installation hardware. Inspect entire main rotor blade assembly for cracks, voids, blisters, or other damage. Inspect bushing holes thru blade. Inspect root plates for cracks. Conduct a tap test of blade upper and lower surface*.	Contact Van Horn Aviation if any discrepancies found exceeding damage limits in 5.10 and for grip plate assembly installation instructions.

5.6 SUDDEN STOPPAGE OR ACCELERATION

No.	Inspection Requirements	Airworthiness Criteria
1.	No inspection required	Remove the rotor blades and return to Van Horn Aviation for evaluation.

5.7 OVERSPEED – 107 PERCENT OR GREATER

No.	Inspection Requirements	Airworthiness Criteria
1.	For main rotor overspeed above 107% up to 114% Inspect main rotor blades for any visible damage such as cracks, blisters, delaminations, or local contour deformation.	No defects permitted.
2.	For main rotor overspeed above 114% Inspect main rotor blades for any visible damage such as cracks, blisters, delaminations, or local contour and dimensionally check main rotor blade attachment bushing for elongation in excess of .0015 inch.	No defects permitted.

5.8 OVERTORQUE

No.	Inspection Requirements	Airworthiness Criteria
1.	No inspection is required for overtorques between 100 to 110 percent.	N/A
2.	Overtorques 110 to 120 percent, Inspect the main rotor blades for any visible damage such as cracks, blisters, delaminations, or local contour deformation. If any of these conditions exist, remove the rotor blades and return to Van Horn Aviation for evaluation.	No defects permitted.
3.	Overtorques above 120 percent require the inspections in Step 2 above at the time of the overtorque and again after 25 hours of operation.	No defects permitted.

5.9 LIGHTNING STRIKE

No.	Inspection Requirements	Airworthiness Criteria
1.	Scrap the blades if there is any evidence of a lightning strike. Return the scraped blades to Van Horn Aviation for testing.	N/A

*The internal structure of the blade will cause tone changes during the tap test. Figure 5-1 shows the blades' internal components with their approximate locations and shapes. Other than the components shown, the remainder of the blades' internal structure is high density structural foam. Tone changes can be expected as the tap test traverses the various blade sections. Tone changes that are not associated with internal component boundaries should be treated as suspected voids.

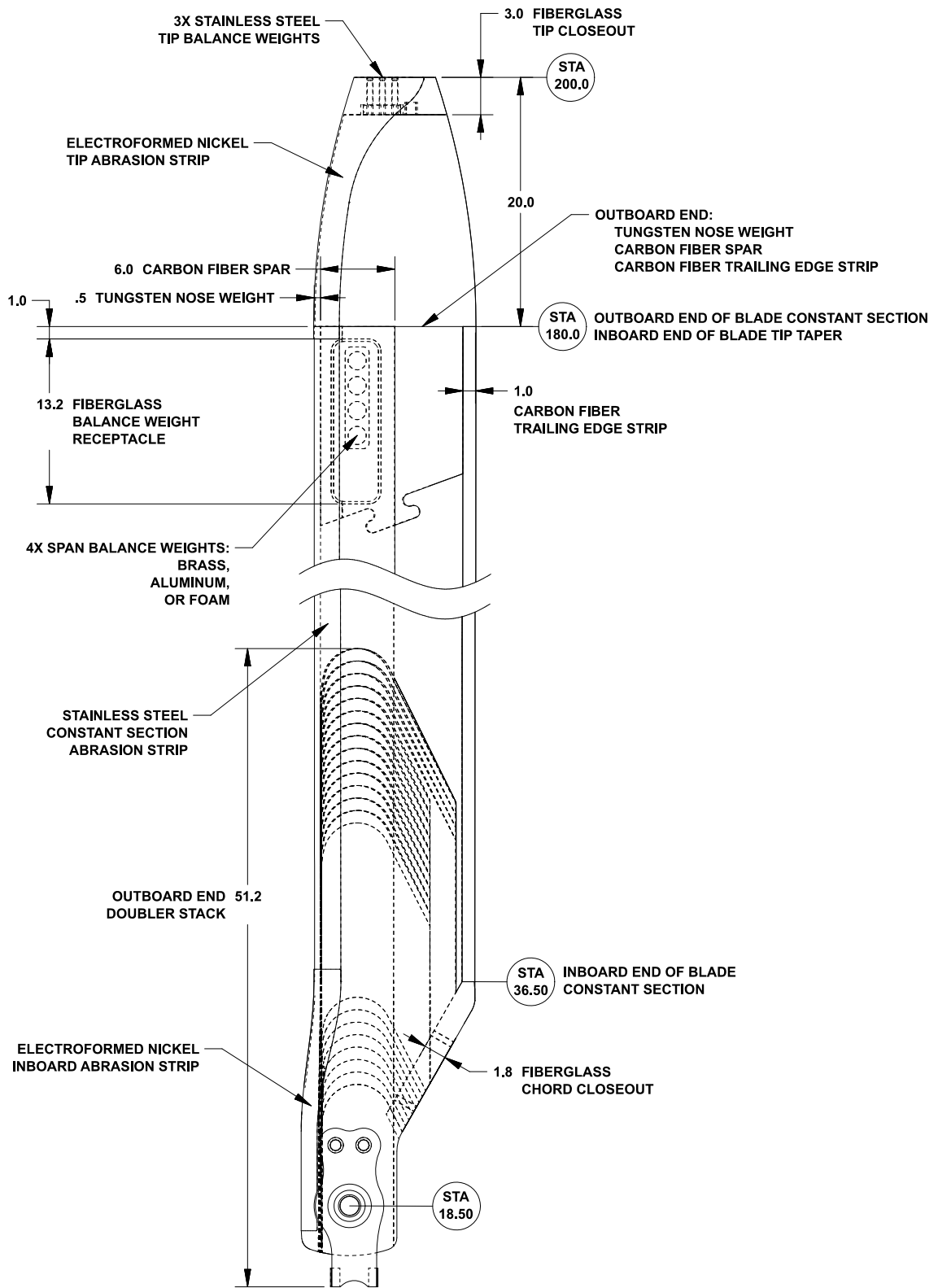

Figure 5-1
Blade Internal Component Locations and Shapes

5.10 DAMAGE LIMITS

5.10.1 Damage Description

Damage may take the form of cracks, scratches, nicks, dents, disbonds, or voids. Limits are provided for each of these types of damage. Damage exceeding these limits require evaluation, and if possible, repair at an authorized FAA repair station. Contact VHA for repair station recommendations.

Carbon/epoxy material strength can be degraded by prolonged exposure to moisture and ultra violet radiation. This rotor blade is protected from both of these conditions using epoxy primer and multiple coats of polyurethane top coat. It is very important to maintain these protective measures throughout the life of the blade by adhering to the 5.10.4 Spot Refinishing requirements.

5.10.2 Abrasion Strips

Three abrasion strips are used on the leading edge. The electroformed nickel inboard abrasion extends from near the inboard end of the blade to approximately STA 37.0. It overlaps the stainless steel constant section abrasion strip which starts at STA 36.0 and extends to STA 180.0. The electroformed nickel tip abrasion strip starts at approximately STA 179.0 and extends to the blade tip. It overlaps the constant section abrasion strip. The criteria below apply to all three abrasion strips.

- a. Non-sharp dents not exceeding 0.050 inch are acceptable at any location.
- b. Sharp dents are not permitted.
- c. Punctures or cracks are not permitted.
- d. Tap test an area 1.0 inch either side of the dent for voids.
- e. Inspect for trailing edge disbond.
- f. If disbonds or voids exist, there is a possibility of underlying carbon fiber damage; therefore, evaluation at an approved FAA repair station is required. Contact VHA for repair station recommendations.
- g. If there are no disbonds or voids, leave the dent exposed so it may be monitored for evidence of cracking in the future.
- h. If abrasion strip is worn thru because of erosion, send blade to an approved FAA repair station for repair. Contact VHA for repair station recommendations.

5.10.3 Skin

Impact damage may progress from little evidence of external damage to puncture with surrounding voids depending on impact force. In all cases of suspected skin damage, a tap test is required to determine extent of the damage.

- a. Voids are not allowed within 1.0 inch of the trailing edge.
- b. Voids not exceeding 1.0 inch diameter are acceptable at any spanwise location.
- c. If voids are detected, remove paint in the damaged area to check for broken fibers. Remove paint and primer only. Do not sand into skin plies.
- d. Broken fibers are not permitted. If broken fibers are detected, send blade to an authorized FAA repair station for evaluation, and if possible, repair. Contact VHA for repair station recommendations
- e. Scratches, nicks, or fiber damage in the extreme trailing edge 0.10 deep or less may be blended out over a distance of at least 2.0 inches each side of the damage. See Figure 5-2 below.
- f. Damage at the tip trailing edge may be removed by blending up to a 1.0 inch radius at the tip. See Figure 5-2 below.

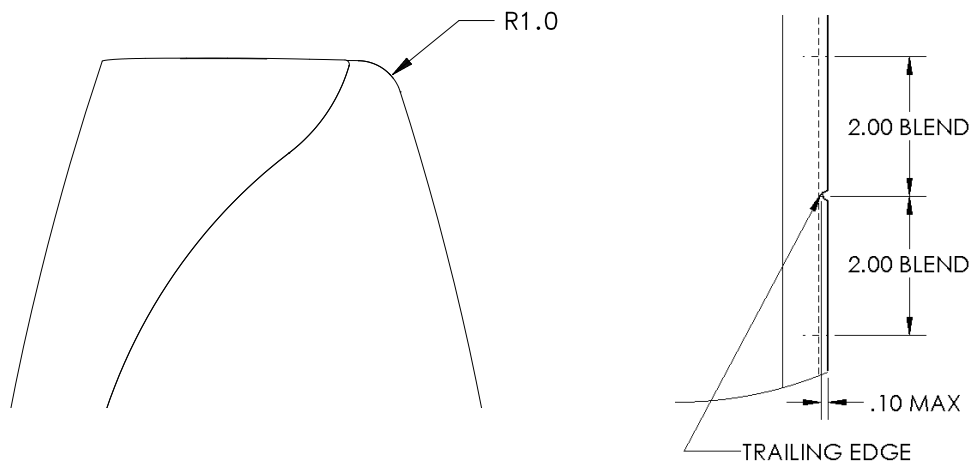

Figure 5-2
Tip and Trailing Edge Damage Limits

5.10.4 Spot Refinishing

VHA finishes the main rotor blade using an epoxy surfacing film co-cured with the skin, epoxy paint primer, and a two stage top coat. First stage is a color coat. Second stage is clear.

- a. When preparing the blade for touch-up, do not sand into skin plies. Primer and surfacing film is gray. Carbon/epoxy skin plies are black. Copper mesh lightning strike protection is bonded over the skin.
- b. A polyurethane film co-cured with the skin protects the tapered tip from STA 180.0 to the tip at STA 200.0. Paint erosion is permitted in this area so long as the polyurethane film has not eroded exposing carbon/epoxy skin.
- c. Exposed carbon/epoxy skin not exceeding 0.50 inch aft of abrasion strip trailing edge must be protected by at least one coat of epoxy primer within 25 flight hours of exposure or 60 days whichever occurs first.
- d. Exposed carbon/epoxy skin exceeding 0.50 inch aft of abrasion strip trailing edge must be protected by at least one coat of epoxy primer within 10 flight hours of exposure or 30 days whichever occurs first.
- e. Paint peeling may occur. Feather paint edges using 320 grit or finer abrasive paper to stop peeling. Touchup paint required for appearance only if black carbon/epoxy skin is not exposed. Touch up exposed skin with one coat of epoxy primer.
- f. Paint nicks and scratches require touchup paint for appearance only if black carbon/epoxy skin is not exposed. Touch up exposed skin with one coat of epoxy primer.
- g. Paint touch-up may be performed using either a two stage or single stage method. Exact matching is difficult using single stage paint, so it is recommended using this method for small areas only. Single stage paint is Axalta Imron Elite SS Single Stage Color. Any aerospace quality polyurethane paint may be substituted. Use a compatible epoxy primer. Two stage paint is Axalta Imron Elite Basecoat Color used with Axalta Imron Elite 8840S Clearcoat.
- h. White paint (upper blade surface except tip) is Axalta color 786255.
- i. Black paint (lower blade surface) is Axalta color 99.
- j. Blue paint (tip upper surface) is Axalta color 7165.
- k. Orange paint (high visibility option) is Axalta color 60659

CHAPTER 11 – PLACARDS AND DECALS

There are no placards or decals associated with this STC.

CHAPTER 62 – MAIN ROTOR BLADE

62.1 DESCRIPTION

The 20631000-101 main rotor blade is a composite and metallic structure incorporating the NASA-developed RC(4)-12(12% thick) rotor blade airfoil. This is a highly efficient laminar flow airfoil developed to have near zero pitching moments across a broad range of airspeeds. The blade radius and chord is the same as the existing production blade except that the tip of the blade is tapered to reduce noise and tip drag. The root fitting is machined titanium alloy plate fastened to the blade root using two .750-inch bolts. Stainless steel bushings are bonded into the root of the blade. The basic blade section is fabricated using unidirectional carbon/epoxy tape and plain weave carbon/epoxy fabric with a rigid cell structural foam core. Span balance is accomplished using cylindrical weights bonded into a fiberglass/epoxy high pressure laminate sheet receptacle and threaded stainless steel screws in a fiberglass/epoxy high pressure laminate tip cap. Electroformed nickel and stainless steel abrasion strips are added for erosion protection.

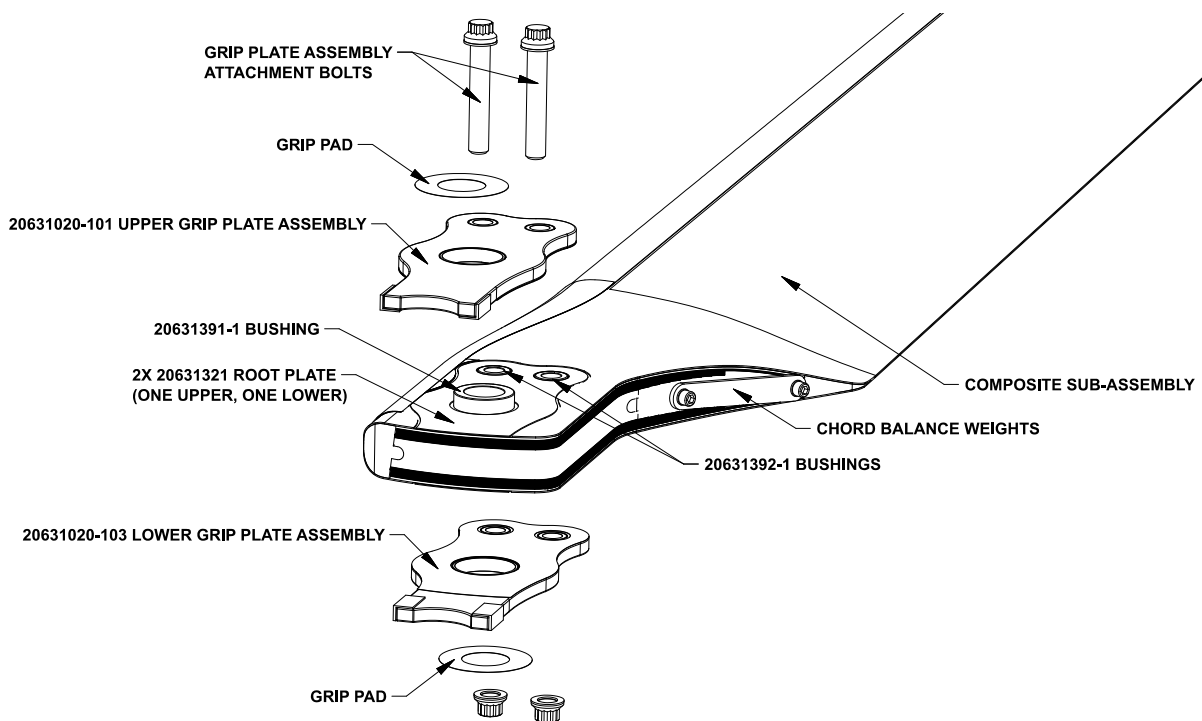

Figure 62-1
Main Rotor Blade Description

62.2 INSTALLATION

20631000-101 main rotor blade assembly is eligible for installation on helicopters modified per T.B. 206-91-133 MAIN ROTOR HUB ASSEMBLY, P/N 206-001-100, CONFIGURATION OF, with the following hub configurations:

206-011-100-011 small hub incorporating grip assembly 206-010-102-121
206-011-100-017 small hub incorporating grip assembly 206-010-102-121
206-011-100-021 small hub incorporating grip assembly 206-010-102-121
206-011-100-all larger hub configurations

Install the 20631000-101 main rotor blade according to the current FAA accepted maintenance manual for existing production main rotor blades 206-010-200-ALL except as follows:

The 20631000-101 main rotor blade incorporates an alignment drive screw positioned on the upper surface of the blade 20 inches inboard of the tip. See figure 62-2. Tape the alignment cord over the alignment screw.

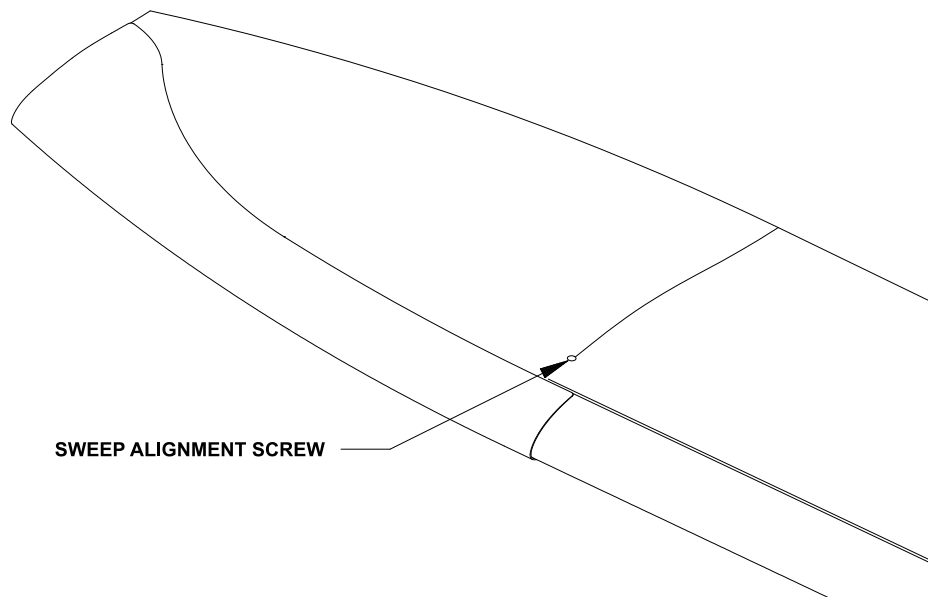

Figure 62-2
Main Rotor Blade Alignment Mark

62.4 STATIC BALANCE OF MAIN ROTOR BLADES

Balance the 20631000-101 main rotor blades according to the current FAA accepted maintenance manual for the existing production main rotor blade 206-010-200-ALL.

62.3 DYNAMIC TRACKING AND BALANCING OF MAIN ROTOR BLADES

The 20631000-101 main rotor blade incorporates a different airfoil, different span and chord weight distribution, and the blade is stiffer. These differences have an effect on how the blades respond to normal adjustments during tracking and balancing. Blade response will be as predicted, but the magnitude of changes to adjustments may be different depending upon the equipment used.

62.3.1 Dynamic Balancing

Dynamically balance the 20631000-101 main rotor blades according to the current FAA accepted maintenance manual for the existing production main rotor blade 206-010-200-ALL.

NOTE

Do not use the three tip weights for balance adjustment.

62.3.2 Dynamic Tracking

Dynamically track 20631000-101 main rotor blades according to the current FAA accepted maintenance manual for the existing production main rotor blade 206-010-200-ALL with the following exceptions and recommended practices.

- a) The 20631000-101 main rotor blade has a single trim tab centered at blade station 150.0. Use tracking instructions for blades with outboard trim tab only.
- b) It is recommended using only pitch links for hover tracking. Use trim tabs for forward flight tracking only.
- c) Use tool 206-CS-T001 for trim tab adjustments. This tool incorporates both the tab bending tool and tab position indicator. Tab position is measured in thousands of an inch from neutral (0 deg. tab angle) position. As an alternate, Bell approved tab bending and angle measuring tools may be used. Use 206-CS-T002 tracking tabs or reflective tape to determine blade track.
- d) It is recommended correcting an out of track condition by equally adjusting one blade up and the other down. Testing has shown that this provides the best method for insuring a smooth track over large airspeed ranges.

62.5 WEIGHT AND BALANCE

The weight of each 20631000-101 main rotor blade is recorded on each blade's historical record (log card). Adjust the helicopter's weight and balance record as required.

62.6 CLEANING

Use a soft cloth and non-caustic, non-abrasive cleaner to clean VHA composite main rotor blades.

62.7 GRIP PAD REPLACEMENT

Grip pad 20631341-1 (see figure 6-3) may be replaced with Bell grip pad 206-010-233-005. Install either the VHA or Bell grip pad according to the current FAA accepted component repair and overhaul (CR&O) manual for the existing production main rotor blade 206-010-200-ALL with the following exceptions and recommended practices.

- a) Titanium grip plate 20631321-1 is not shot peened. CR&O caution is N/A.

62.8 WEAR PAD REPLACEMENT

Wear pad 20631342-1 (see figure 6-3) may be replaced with Bell wear pad 206-010-242-003. Install either the VHA or Bell wear pad according to the current FAA accepted component repair and overhaul (CR&O) manual for the existing production main rotor blade 206-010-200-ALL with the following exceptions and recommended practices.

- a) Titanium grip plate 20631321-1 is not shot peened. CR&O caution is N/A.
- b) Sweep check is not required.
- c) Blade alignment is required after wear pad replacement.

62.9 GRIP PLATE ASSEMBLY REPLACEMENT

Contact VHA for 20631020-101, -103 grip plate assembly, 20631391-1 bushing, and 20631392-1 bushing replacement.

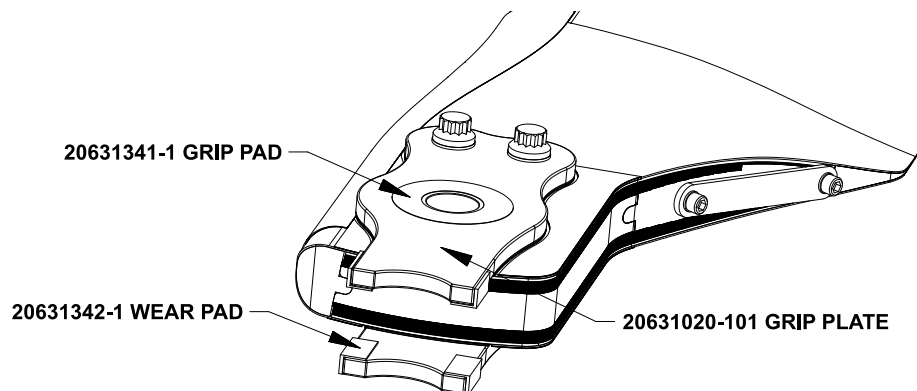

Figure 62-3
Main Rotor Blade Root Assembly