

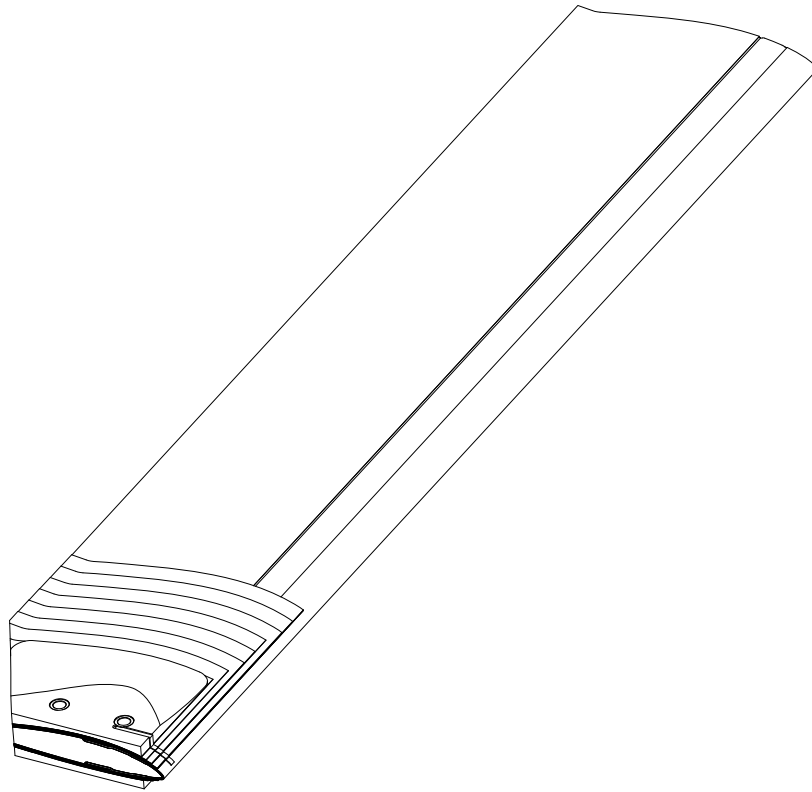

Van Horn Aviation, L.L.C.
1510 West Drake Drive
Tempe, Arizona 85283

INSTRUCTIONS FOR CONTINUED AIRWORTHINESS



ICA MANUAL No. VMM-UH1-305

Tail Rotor Blade Assembly 2042200-101/-103
Eligible for Installation on Richard's Heavylift Helo, Inc.
(S.M. & T.) UH-1H
Reference Van Horn Aviation, L.L.C. STC SR02051LA

REVISIONS

REV	DATE	DESCRIPTION	APPROVED
N/C	04/09/07	Initial Release	JVH
A	06/25/12	Revised ICA to incorporate Van Horn Aviation's new address and new Type Certificate Holder.	JVH
B	01/20/17	Added -103 Configuration. Revised 0.4.2 to correct Van Horn Aviation mailing address. Revised 0.5.2 to change distribution of revisions. Revisions will be not be distributed to original purchaser. They will be added to the VHA website.	JVH

TABLE OF CONTENTS

REVISIONS..... 2
TABLE OF CONTENTS..... 3
CHAPTER 0 - INTRODUCTION 4
CHAPTER 4 – AIRWORTHINESS LIMITATIONS 5
CHAPTER 5 – INSPECTION REQUIREMENTS 6
CHAPTER 11 – PLACARDS AND DECALS 7
CHAPTER 62 – TAIL ROTOR BLADE..... 7

CHAPTER O - INTRODUCTION

0.1 SCOPE

This manual contains information, descriptions, and instructions essential for the continued airworthiness of the Van Horn Aviation L.L.C. (VHA) 2042200-101/-103 Tail Rotor Blade Assembly.

0.2 ARRANGEMENT

This manual follows the Airline Transport Association (ATA) specification 100 numbering system where practical.

0.3 UNITS OF MEASUREMENT

All measurements, tolerances, and other numbers referenced in this manual will be in English units.

0.4 CHANGES TO THE ICA

0.4.1 Changes to text and tables, including new material on added pages shall be indicated by a vertical bar in the outer margin extending close to the entire area of the material affected.

0.4.2 Please send any comments or corrections to Van Horn Aviation L.L.C., 1510 West Drake Drive, Tempe, Arizona, 85283 USA. Or call 01-480-483-4202.

0.5 DISTRIBUTION

0.5.1 The ICA will be shipped with the original purchase of a 2042200-101/-103 tail rotor blade assembly.

0.5.2 Revisions to the ICA will be posted on the VHA website: www.vanhornaviation.com.

CHAPTER 4 – AIRWORTHINESS LIMITATIONS

4.1. AIRWORTHINESS LIMITATIONS SCHEDULE

Part Number	Part Name	Airworthiness Limitation
2042200-101/-103	Tail Rotor Blade	2400 Hours

FAA Approved:



Federal Aviation Administration
Manager, Los Angeles Aircraft Certification Office
Transport Airplane Directorate

Date:

3/16/17

CHAPTER 5 – INSPECTION REQUIREMENTS

5.1. PRIOR TO THE FIRST FLIGHT OF THE DAY

No.	Inspection Requirements	Airworthiness Criteria
1.	Visually check the general condition of the rotor blade.	No obvious damage.

5.2. 100 HOUR INSPECTION AND ANNUALLY

No.	Inspection Requirements	Airworthiness Criteria
1.	Check the general condition of the rotor blade. Check for skin dents, scratches, or blisters. Check the trailing edge for, nicks, or delaminations.	Contact Van Horn Aviation if any discrepancies found.
2.	Inspect the root end doublers and grip plates for edge voids.	Contact Van Horn Aviation if any discrepancies found.
3.	Inspect the abrasion strip for wear and edge voids.	Contact Van Horn Aviation if any discrepancies found.

5.3. SUDDEN STOPPAGE OR ACCELERATION

No.	Inspection Requirements	Airworthiness Criteria
1.	Remove the rotor blade and return to Van Horn Aviation for evaluation.	

5.4. OVERSPEED, OVERTORQUE, OR LIGHTNING STRIKE

No.	Inspection Requirements	Airworthiness Criteria
1.	Use criteria in TM 55-1520-210-23-1. Return rotor blade to Van Horn Aviation if further evaluation is required per the helicopter maintenance manual.	

CHAPTER 11 – PLACARDS AND DECALS

There are no placards or decals associated with this STC.

CHAPTER 62 – TAIL ROTOR BLADE

62.1 DESCRIPTION

The 2042200-101/-103 tail rotor blade is an all composite blade employing an advanced highly efficient airfoil. The blade length is the same as the existing production blade, but the width of the blade is .80 inches longer. Erosion protection is provided by a full span stainless steel abrasion strip adhesively bonded to the leading edge. Stainless steel bushings are pressed into the inboard end to react the attachment bolt loads. The blade is constructed primarily of carbon/epoxy unidirectional tape. The grip plates, tip closure and root closure are fabricated from fiberglass/epoxy fabric. The blade is statically balanced at the factory using a brass balance weight threaded into the tip closure. The interior of the blade is filled with closed cell rigid foam. The only difference between the -101 and -103 configurations is the doubler outboard trim.

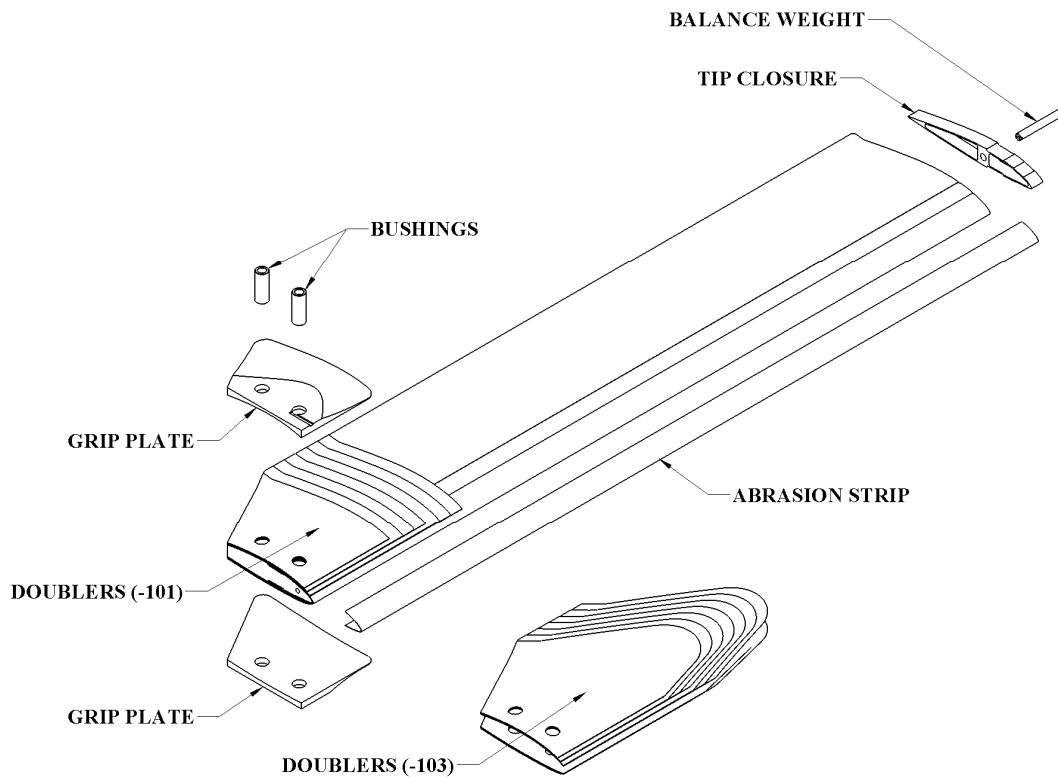

Figure 60.2.1
Tail Rotor Blade Description

62.2 INSTALLATION

Install the 2042200-101/-103 tail rotor blade per maintenance manual TM 55-1520-210-23-1.

NOTE

The 2042200-103 tail rotor blade cannot be intermixed with the 2042200-101 tail rotor blade

62.3 CONTROL RIGGING

Control rigging for the 2042200-101/-103 tail rotor blade is accomplished in exactly the same manner as the production tail rotor blade except for installation of the tail rotor control chain.

Maintenance manual TM 55-1520-210-23-2 calls for the sprocket position to be 1 1/4 to 2 1/4 from bottoming out. Rig the 2042200-101/-103 tail rotor blade by positioning the sprocket 2 additional teeth from bottoming out. The note in the rigging section of the maintenance manual should now read;

NOTE

Relocate chain as necessary on sprocket to assure 3 1/4 TO 4 1/4 teeth movement of sprocket from bottom out. Verify by repeating steps g and h above.

62.4 TRACK AND BALANCE

Track and balance the 2042200-101/-103 tail rotor blade per maintenance manual TM 55-1520-210-23-1 using chart No. 4020 and balance arms No. 4016.

62.6 WEIGHT AND BALANCE

The 2042200-101/-103 tail rotor blade is approximately 0.5 lbs. lighter than the 204-011-702-015 tail rotor blade. The tail rotor blades are at an arm of 479.4. Weigh the blades before installation and enter the data on the aircraft CHART C – BASIC WEIGHT AND BALANCE RECORD.

62.6 MAINTENANCE FLIGHT CHECK

Establish 90 knot (nose mounted), 100 knot (roof mounted) level flight cruise at 30 psi torque. Right pedal should be 0.25" to 1.25" forward of left pedal.

WARNING

Lack of proper pedal position is cause to terminate flight. Adjustments are to be made prior to proceeding with the test flight

NOTE

With hydraulics off a significantly higher force will be required to move the left pedal forward than to move the right pedal forward