

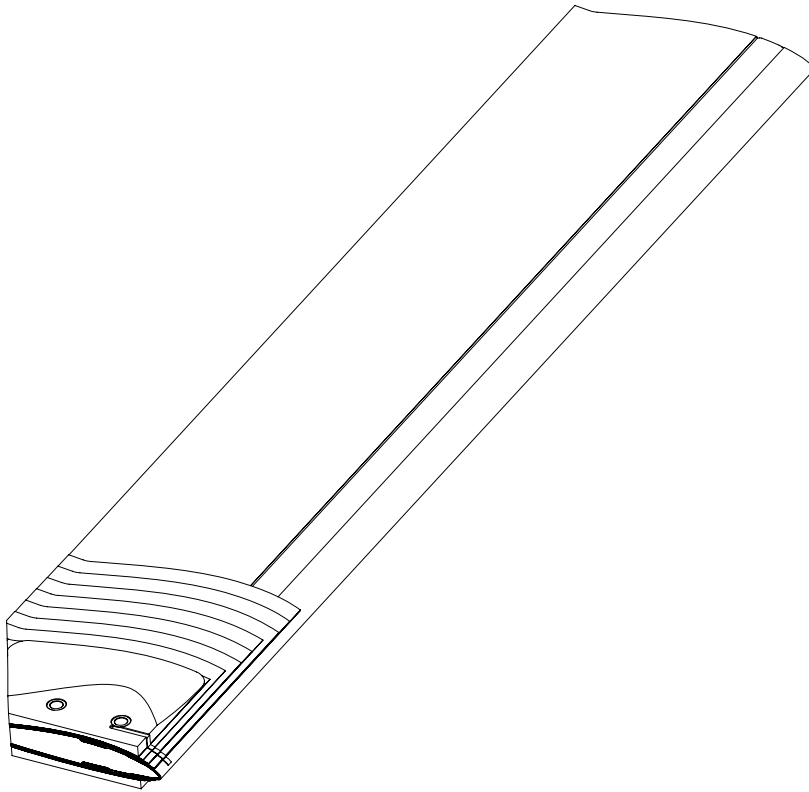

**Van Horn Aviation, L.L.C.**  
*1510 W. Drake Drive*  
*Tempe, Arizona 85283*

## **INSTRUCTIONS FOR CONTINUED AIRWORTHINESS**



### **ICA MANUAL No. VMM-UH1F-308**

**Tail Rotor Blade Assembly 2042200-101**  
**Eligible for Installation on Rotorcraft Development Corporation**  
**(Garlick) UH-1F, TH-1F, UH-1P Helicopters**  
**Reference Van Horn Aviation, L.L.C. STC SR02051LA**

**REVISIONS**

REV	DATE	DESCRIPTION	APPROVED
N/C	4/9/07	Initial Release	JVH
A	6/25/12	Revised ICA to incorporate Van Horn Aviation's new address and new Type Certificate Holder.	JVH

**TABLE OF CONTENTS**

REVISIONS ..... 2  
TABLE OF CONTENTS ..... 3  
CHAPTER 0 - INTRODUCTION ..... 4  
CHAPTER 4 – AIRWORTHINESS LIMITATIONS ..... 5  
CHAPTER 5 – INSPECTION REQUIREMENTS ..... 6  
CHAPTER 11 – PLACARDS AND DECALS ..... 7  
CHAPTER 62 – TAIL ROTOR BLADE..... 7

## **CHAPTER O - INTRODUCTION**

### **0.1 SCOPE**

This manual contains information, descriptions, and instructions essential for the continued airworthiness of the Van Horn Aviation L.L.C. 2042200-101 Tail Rotor Blade Assembly.

### **0.2 ARRANGEMENT**

This manual follows the Airline Transport Association (ATA) specification 100 numbering system where practical.

### **0.3 UNITS OF MEASUREMENT**

All measurements, tolerances, and other numbers referenced in this manual will be in English units.

### **0.4 CHANGES TO THE ICA**

0.4.1 Changes to text and tables, including new material on added pages shall be indicated by a vertical bar in the outer margin extending close to the entire area of the material affected.

0.4.2 Please send any comments or corrections to Van Horn Aviation L.L.C., P.O. Box 12110, Tempe, Arizona, 85284 USA. Or call 01-480-483-4202.

### **0.5 DISTRIBUTION**

0.5.1 The ICA will be shipped with the original purchase of a 2042200-101 tail rotor blade assembly.

0.5.2 Revisions to the ICA will be distributed to original purchaser of the rotor blade.

**CHAPTER 4 – AIRWORTHINESS LIMITATIONS**

**4.1. AIRWORTHINESS LIMITATIONS SCHEDULE**

<b>Part Number</b>	<b>Part Name</b>	<b>Airworthiness Limitation</b>
2042200-101	Tail Rotor Blade	2400 Hours

FAA Approved: \_\_\_\_\_

  
Federal Aviation Administration  
Manager, Los Angeles Aircraft Certification Office  
Transport Airplane Directorate

Date: \_\_\_\_\_

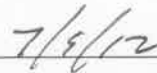

**CHAPTER 5 – INSPECTION REQUIREMENTS**

**5.1. PRIOR TO THE FIRST FLIGHT OF THE DAY**

No.	Inspection Requirements	Airworthiness Criteria
1.	Visually check the general condition of the rotor blade.	No obvious damage.

**5.2. 100 HOUR INSPECTION AND ANNUALLY**

No.	Inspection Requirements	Airworthiness Criteria
1.	Check the general condition of the rotor blade. Check for skin dents, scratches, or blisters. Check the trailing edge for, nicks, or delaminations.	Contact Van Horn Aviation if any discrepancies found.
2.	Inspect the root end doublers and grip plates for edge voids.	Contact Van Horn Aviation if any discrepancies found.
3.	Inspect the abrasion strip for wear and edge voids.	Contact Van Horn Aviation if any discrepancies found.

**5.3. SUDDEN STOPPAGE OR ACCELERATION**

No.	Inspection Requirements	Airworthiness Criteria
1.	Remove the rotor blade and return to Van Horn Aviation for evaluation.	

**5.4. OVERSPEED, OVERTORQUE, OR LIGHTNING STRIKE**

No.	Inspection Requirements	Airworthiness Criteria
1.	Remove the rotor blade and return to Van Horn Aviation for evaluation.	

## CHAPTER 11 – PLACARDS AND DECALS

There are no placards or decals associated with this STC.

## CHAPTER 62 – TAIL ROTOR BLADE

### **62.1 DESCRIPTION**

The 2042200-101 tail rotor blade is an all composite blade employing an advanced highly efficient airfoil. The blade length is the same as the existing production blade, but the width of the blade is .80 inches longer. Erosion protection is provided by a full span stainless steel abrasion strip adhesively bonded to the leading edge. Stainless steel bushings are pressed into the inboard end to react the attachment bolt loads. The blade is constructed primarily of carbon/epoxy unidirectional tape. The grip plates, tip closure and root closure are fabricated from fiberglass/epoxy fabric. The blade is statically balanced at the factory using a brass balance weight threaded into the tip closure. The interior of the blade is filled with closed cell rigid foam.

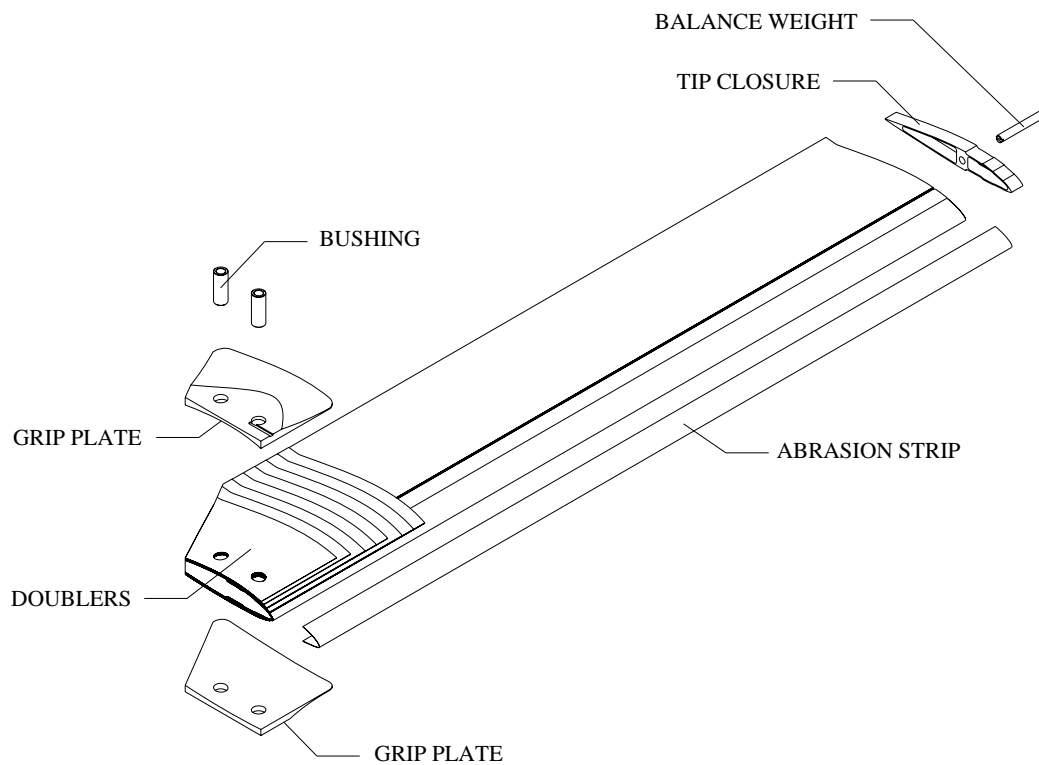

Figure 60.2.1  
Tail Rotor Blade Description

## **62.2 INSTALLATION**

Install the 2042200-101 tail rotor blade per maintenance manual T.O. UH-1(U)F-2-1.

## **62.3 CONTROL RIGGING**

Control rigging for the 2042200-101 tail rotor blade is accomplished in exactly the same manner as the production tail rotor blade except for installation of the tail rotor control chain.

Maintenance manual T.O. UH-1(U)F-2-1 calls for the sprocket position to be 1 1/4 to 2 1/4 from bottoming out. Rig the 2042200-101 tail rotor blade by positioning the sprocket 2 additional teeth from bottoming out. The note in the rigging section of the maintenance manual should now read;

### **NOTE**

**Relocate chain as necessary on sprocket to assure 3 1/4 TO 4 1/4 teeth movement of sprocket from bottom out. Verify by repeating steps l. and m. below.**

## **62.4 TRACK AND BALANCE**

Track and balance the 2042200-101 tail rotor blade per maintenance manual T.O. UH-1(U)F-2-1 using chart No. 4020 and balance arms No. 4016.

## **62.6 WEIGHT AND BALANCE**

The 2042200-101 tail rotor blade is approximately 0.5 lbs. lighter than the 204-011-702-015 tail rotor blade. The tail rotor blades are at an arm of 477.22. Weigh the blades before installation and enter the data on the aircraft CHART C – BASIC WEIGHT AND BALANCE RECORD.